

FCF1103 (Heavy Duty Ground Stake HGS) - INSTALLATION INSTRUCTIONS

CAUTION: BEFORE CONNECTING THE FIXTURE TO A POWER SUPPLY, MAKE SURE THE POWER IS SWITCHED OFF.

Includes: FCF1103 only.

GENERAL:

1. Before starting the installation, make sure all electricity has been turned off and electrical breaker has been locked out and tagged out.
2. To ensure the success of the installation, be sure to read these instructions and review the diagrams thoroughly before beginning.
3. All electrical connections must be in accordance with local codes, ordinances, or the National Electrical Code.
4. This product must be installed in accordance with national and local electrical and construction codes by a person familiar with the construction and operation of the product and the hazards involved. Failure to comply with the following instructions may result in injury or death.

NOTE: The important safeguards and instructions appearing in this document are not meant to cover all possible conditions, equipment and situations that may occur.

WARNING:

- Disconnect power to avoid electrical shock.
- Do not exceed fixture specified voltage.
- Do not use if any parts are damaged.
- Unauthorized field repair will void warranty.
- Retain all gaskets and hardware for reuse.

NOTE: LEDs are integral and NOT intended for general servicing.

- 1) Remove the contents from inside the Ground Stake. Confirm that there are four "Fins" and four Screws.
- 2) Assemble the Fins of the Stabilizer Grid by mating them together using the two slots in each Fin. **Fig. 1**
- 3) Once the Stabilizer Grid is assembled it should look like this from the top view. **Fig. 2**
- 4) Slide the Stake in through the middle square of the Fin assembly Grid.
- 5) Secure the Fins to the Stake by screwing the (4) supplied Screws directly into the side of the Stake. **Note:** Recommended Fin height is 10 inches from the bottom of the Stake. **Fig. 3**
- 6) Finished Ground Stake assembly. **Fig. 4**
- 7) Loosen Screw only and Remove the Top Mount Cap. **Fig. 5** Set it aside for fixture setup.

Installing Stake In Ground

- 8) Excavate for conduit lines and Stake post. Consider climate like snowfall conditions when determining the post height above ground.
- 9) Dig a Hole where the Stake will be installed, approximately 10 inches in diameter and 8.25 inches deep. **Fig. 6** Stake should stand approximately 3 inches above ground. Silicone Wire Nuts and Waterproof Junction Box should be used for wiring connections.
- 10) Feed the Lead Wire from the J-box up through the Ground Stake tube and tuck the excess wire back in the top of the tube. **Fig. 7**
- 11) Position the Ground Stake in the center of the excavated hole and, if needed, place a flat 2"x 4" piece of wood or equivalent on top of the Stake tube and tap on it level to sink the post 7.5 inches into the ground. **Fig. 9**

Continue next page ...

DETAILED ILLUSTRATION

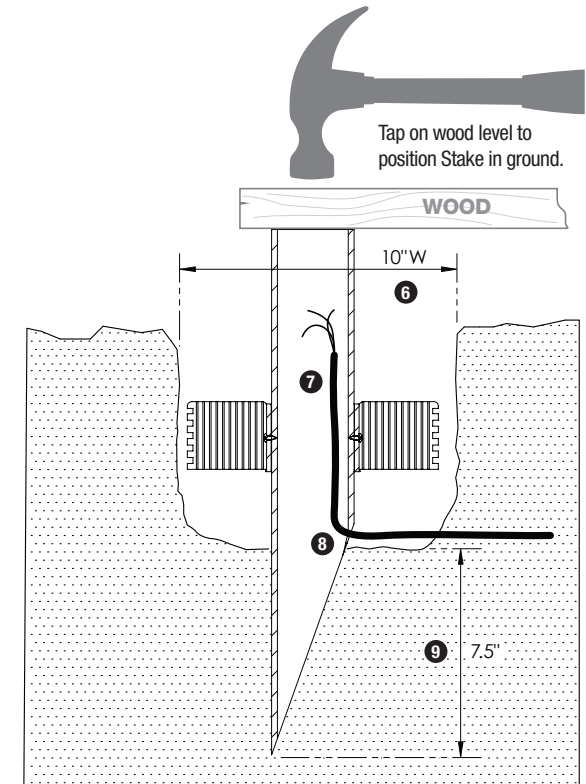
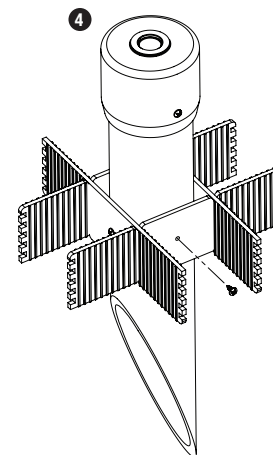
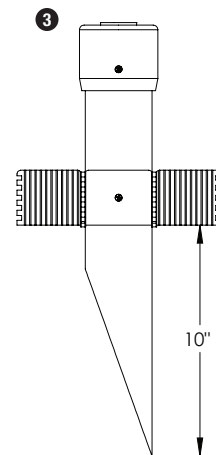
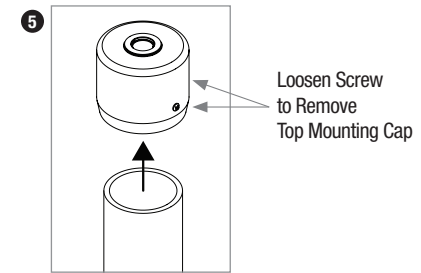
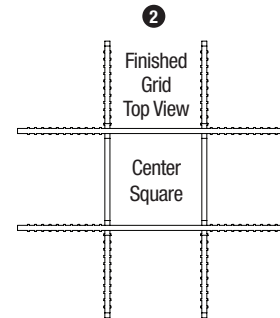
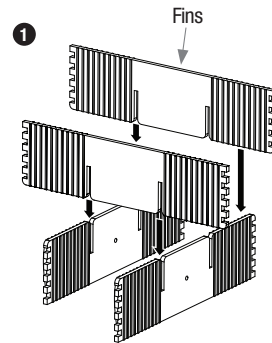

corporate
t 800.900.1730
3609 Swenson Ave.
St. Charles, IL 60174



Tap on wood level to position Stake in ground.

WOOD

10" W

6

7

8

9

7.5"

RG-DM-101523

FCF1103 (Heavy Duty Ground Stake HGS) - INSTALLATION INSTRUCTIONS

CAUTION: BEFORE CONNECTING THE FIXTURE TO A POWER SUPPLY, MAKE SURE THE POWER IS SWITCHED OFF.

Includes: FCF1103 only.

DETAILED ILLUSTRATION



FC 
OUTDOOR LIGHTING

corporate
t 800.900.1730
3609 Swenson Ave.
St. Charles, IL 60174

GENERAL:

1. Before starting the installation, make sure all electricity has been turned off and electrical breaker has been locked out and tagged out.
2. To ensure the success of the installation, be sure to read these instructions and review the diagrams thoroughly before beginning.
3. All electrical connections must be in accordance with local codes, ordinances, or the National Electrical Code.
4. This product must be installed in accordance with national and local electrical and construction codes by a person familiar with the construction and operation of the product and the hazards involved. Failure to comply with the following instructions may result in injury or death.

NOTE: The important safeguards and instructions appearing in this document are not meant to cover all possible conditions, equipment and situations that may occur.

WARNING:

- Disconnect power to avoid electrical shock.
- Do not exceed fixture specified voltage.
- Do not use if any parts are damaged.
- Unauthorized field repair will void warranty.
- Retain all gaskets and hardware for reuse.

NOTE: LEDs are integral and NOT intended for general servicing.

Install Continued ...

NOTE: Once the Ground Stake (HGS) is in position you can backfill around the post with gravel for added stability, and add dirt at the surface. **Fig 10**

- 12) Loosen the Cord Grip on the fixture Mounting Bracket, pass the Wiring through the Mounting Cap, then torque the bottom nut on the Cord Grip onto the Mounting Cap to 8 lbf-in (.66lb-ft) [.90 N-m]. **Fig 11**
- 13) Complete the wiring connections from the Fixture to the Lead Wires inside the Stake tube using Silicone Wire Nuts.
- 14) Place the Mounting Cap over the Ground Stake, push the Cap down flush and tighten in place using the philips head Set Screw provided. **Fig 12**
- 15) Set the Swivel Light Adjustment to desired position and tighten in place. **Fig 13**
- 16) To adjust the Vertical Light Direction loosen the center M6 5mm Drive Hex Head Screw on the Mounting Bracket assembly, once adjusted to the desired position torque the screw to 15 lbf-in (1.25 lbf-ft) [1.69 N-m]. **Fig 14**
- 17) Illustration of complete installation. **Fig 15**
- 18) Apply power to fixture and test for proper operation.

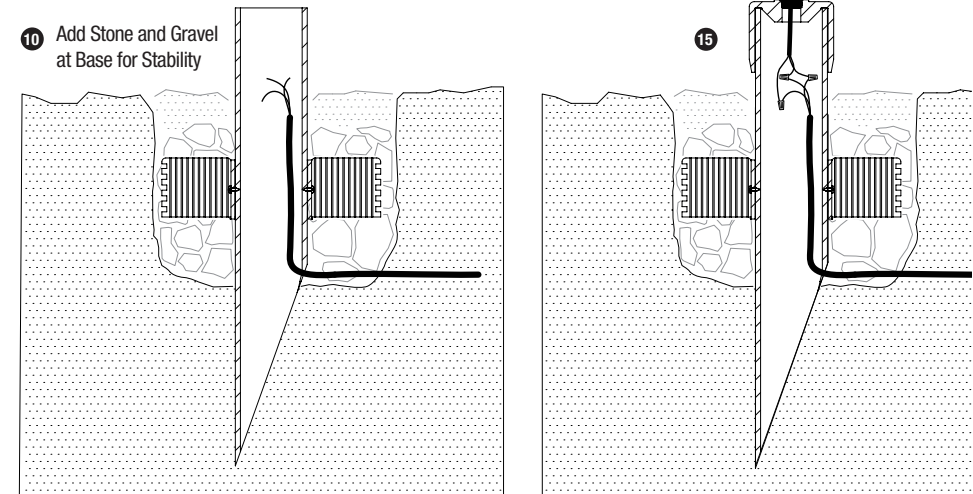
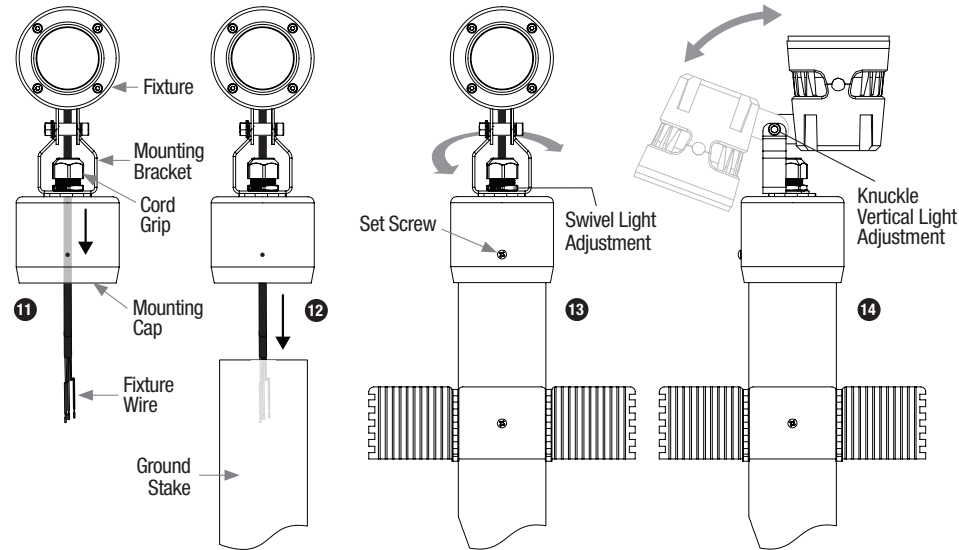

RG-DM-101523

FCF1103 (Ground Stake GS) - INSTALLATION INSTRUCTIONS

CAUTION: BEFORE CONNECTING THE FIXTURE TO A POWER SUPPLY, MAKE SURE THE POWER IS SWITCHED OFF.

Includes: FCF1103 only.

DETAILED ILLUSTRATION



FC 
OUTDOOR LIGHTING

corporate
t 800.900.1730
3609 Swenson Ave.
St. Charles, IL 60174

GENERAL:

1. Before starting the installation, make sure all electricity has been turned off and electrical breaker has been locked out and tagged out.
2. To ensure the success of the installation, be sure to read these instructions and review the diagrams thoroughly before beginning.
3. All electrical connections must be in accordance with local codes, ordinances, or the National Electrical Code.

NOTE: The important safeguards and instructions appearing in this manual are not meant to cover all possible conditions and situations that may occur.

INSTALLATION INSTRUCTIONS:

NOTE: LED lamping is integral and NOT intended for general servicing.

- 1) The Standard Mounting Bracket that comes with the FCF1103 can be used to attach the fixture to the Ground Stake using the supplied Hex Bolt.
- 2) Once the fixture is attached to the Ground Stake, make sure the Adjustment Screw is tight before attempting to push the Stake into the ground.
- 3) Pinpoint the position on the ground to install the fixture. Grasp the fixture with one hand around the Mounting Bracket and one hand firmly on top of the fixture. Press the Stake into the ground until the Stake Top is flush with the ground surface. **Fig. A**
- 4) Complete wiring connections to add power to the fixture, following NEC and local codes.
- 5) Test fixtures to make sure they're properly powered.
- 6) Loosen the M6 5mm Drive Adjustment Screw to tilt the fixture and aim the light to the desired height. Then torque to 15 lbf-in (1.25 lbf-ft) [1.69 N-m]. Loosen the 4mm Drive Hex Bolt to pivot the fixture and change the light direction. Then torque to 15 lbf-in (1.25 lbf-ft) [1.69 N-m].
- 7) If you need to remove a fixture to relocate it, first loosen the ground around the Stake, gently remove the fixture and stake, then repeat step 3 above to reinstall the fixture.

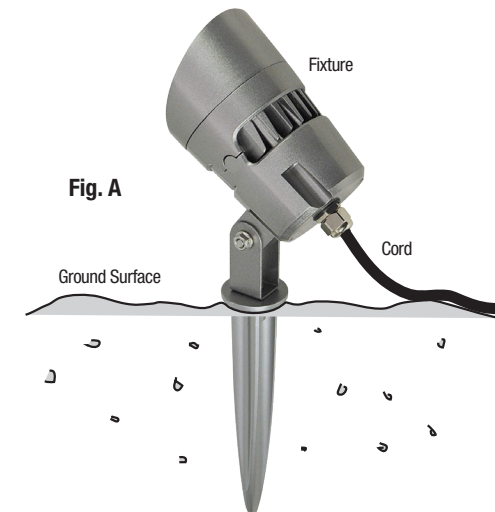
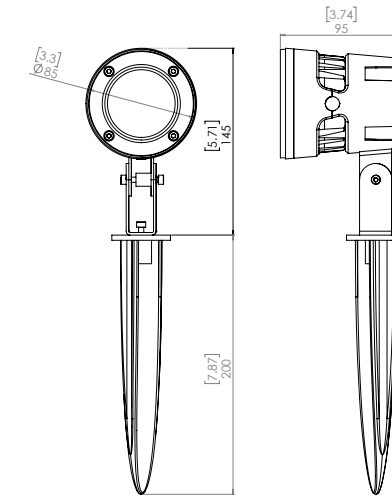
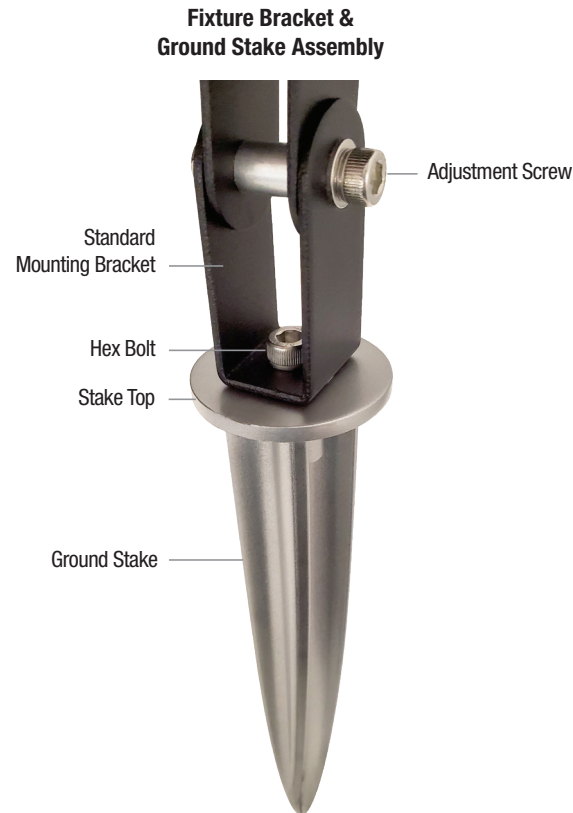

RG-DM-101523

©2023 FC LIGHTING, INC.

FCF1103 (Yoke Y to Surface, Whip to J-box) - INSTALLATION INSTRUCTIONS

CAUTION: BEFORE CONNECTING THE FIXTURE TO A POWER SUPPLY, MAKE SURE THE POWER IS SWITCHED OFF.

Includes: FCF1103, FCF1105, FCF1106, FCF1109, SSF2105, SSF2106 and SSF2109 only.

DETAILED ILLUSTRATION



FC 
OUTDOOR LIGHTING

corporate
t 800.900.1730
3609 Swenson Ave.
St. Charles, IL 60174

GENERAL:

1. Before starting the installation, make sure all electricity has been turned off and electrical breaker has been locked out and tagged out.
2. To ensure the success of the installation, be sure to read these instructions and review the diagrams thoroughly before beginning.
3. All electrical connections must be in accordance with local codes, ordinances, or the National Electrical Code.

NOTE: The important safeguards and instructions appearing in this manual are not meant to cover all possible conditions and situations that may occur.

INSTALLATION INSTRUCTIONS:

NOTE: LED lamping is integral and NOT intended for general servicing.

- 1) Determine location and orientation of fixture on mounting surface. Fixture must be within 12" of J-box. NOTICE: Fixture can only be adjusted on one axis after mounting.
- 2) Mark two outer mounting holes thru the yoke on the FCF1105/SSL2105, FCF1106/SSL2106 and FCF1109/SSL2109. On the FCF1103 mark the center hole for mounting.



Note: These instructions do not cover all details or variations in equipment nor do they provide for every possible situation during installation.

- 3) Drill and insert appropriate anchor(s) for surface material and fixture weight. 1/4" x 20 bolts recommended (provided by others). Using bolts and locking washers, attach fixture firmly to the mounting surface.

- 4) Feed cord thru cord grip and J-box cover (by others).
- 5) Connect wires to incoming power. Black = Line, White = Neutral, Green = Ground, 0-10V Dimming option: Violet = (+) dimming, Pink = (-) dimming.
- 6) Re-attach J-box cover.

