

FCA5500 - INSTALLATION INSTRUCTIONS

CAUTION: BEFORE CONNECTING THE FIXTURE TO A POWER SUPPLY, MAKE SURE THE POWER IS SWITCHED OFF.



DETAILED ILLUSTRATION

GENERAL:

1. Before starting the installation, make sure all electricity has been turned off and electrical breaker has been locked out and tagged out.
2. To ensure the success of the installation, be sure to read these instructions and review the diagrams thoroughly before beginning.
3. All electrical connections must be in accordance with local codes, ordinances, or the National Electrical Code.

NOTE: The important safeguards and instructions appearing in this manual are not meant to cover all possible conditions and situations that may occur.

1) FOOTING DESIGN:

All footings should be poured to direct water away from the base of the fixture. Drainage should be provided to prevent water from collecting under and around the fixture. Anchors must be located per the dimensions shown. Anchor Bolts are galvanized steel. The unthreaded portion should be in the concrete and the threaded portion should be above the concrete.

2) INSTALL MOUNTING BASE:

Remove the column housing from the bottom of mounting base by removing the (6) flat head screws around the bottom edge of the housing. Once the footing is set and level, install the mounting base. Place a continuous bead of silicone between the mounting base and the ground. Tighten nuts snug to hold base in place. **TIGHTEN EVENLY AND DO NOT OVERTIGHTEN.**

3) WIRING:

Make wiring connections. All wiring connections must be made in accordance with local electrical codes, ordinances, and the National Electric Code.

- 4) Place column housing over mounting base. Tighten the (6) set screws evenly until fixture is held firmly in position.

• Set Screw Size: 1/4-20 • Bit Size: 1/8" hex • Torque: 50 in-lb

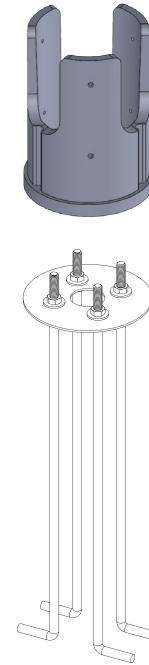
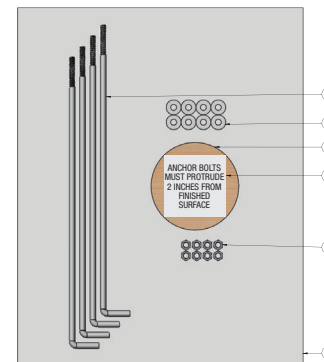
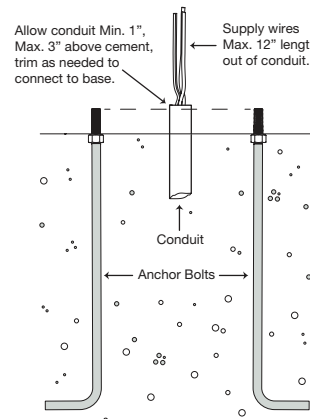
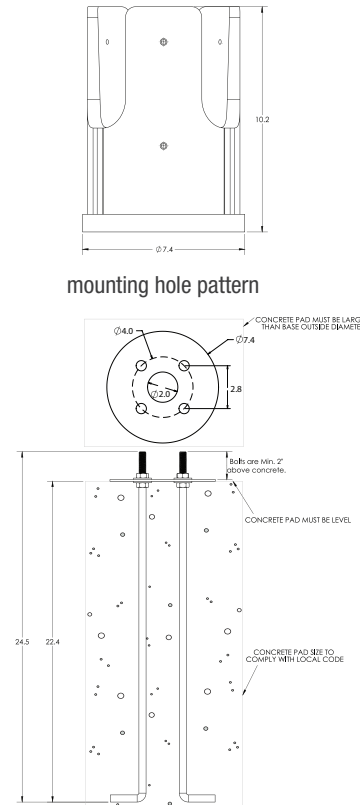
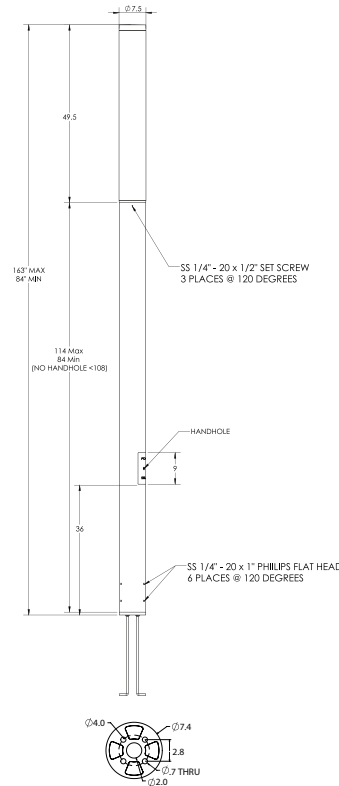

#	ANCHOR BOLT TEMPLATE ASSEMBLY (A05502) (Includes below items)	QTY.
1	1/2" x 24" x 2" L hook Anchor Bolt (91120)	4
2	1/2" FLAT WASHER H-D GALV STEEL	8
3	ANCHOR BOLT WOOD TEMPLATE	1
4	ANCHOR BOLT LABEL	1
5	1/2"-13 HEX NUT H-D GALV STEEL	8
6	PLASTIC BAG, SEALED	1

COLOR CODE			120VAC-277VAC
UNV	BLACK	L	
DIMMING	WHITE	N	+10VDC
	GREEN	GRND	
	VIOLET	+	
	PINK	-	

FCA5500 - DOOR ASSEMBLY INSTALLATION INSTRUCTIONS

CAUTION: BEFORE CONNECTING THE FIXTURE TO A POWER SUPPLY, MAKE SURE THE POWER IS SWITCHED OFF.



DETAILED ILLUSTRATION

ASSEMBLY DOOR:

1. Use bracket and screw to lock door assembly in place. **Fig A**
2. Place bracket against housing wall. Tighten until secure. **Fig B**

NOTE: Screw: M8x20mm
Drive Type: HEX 6mm
Torque: 15 in-lb

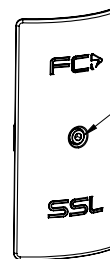
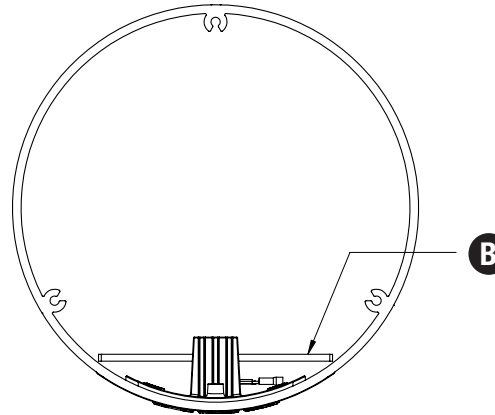

Screw: M8x20mm
Drive Type: HEX 6mm
Torque: 15 in-lb

